

Tous droits strictement réservés. Reproduction ou communication à des tiers interdite sous quelque forme que ce soit sans autorisation écrite du propriétaire. Propriété de c FCI. Droits de reproduction FCI.

All rights strictly reserved. Reproduction or issue to third parties in any form whatever is not permitted without written authority from the proprietor. Property of FCI. Copyright FCI.

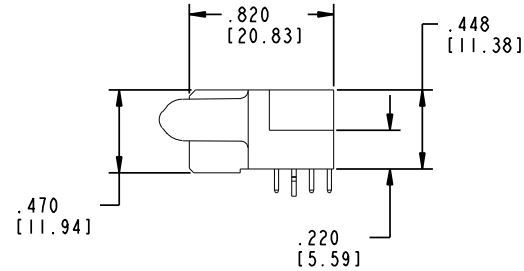
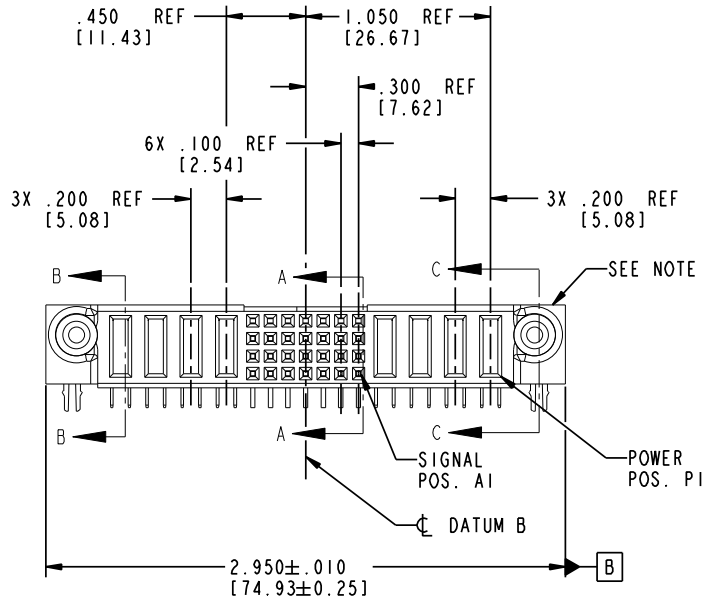
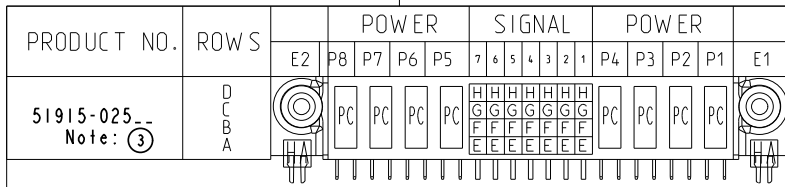

CODE	DIM "M" MATING LENGTH	CONTACT TYPE
E	N/A [N/A]	SIGNAL
F	N/A [N/A]	SIGNAL
G	N/A [N/A]	SIGNAL
H	N/A [N/A]	SIGNAL
HA	N/A [N/A]	HOLD-DOWN
PC	.092 [2.34]	POWER

mat'l code SEE NOTE 2				tolerances unless otherwise specified				CUSTOMER		 www.fciconnect.com	
ltr	ecn no.	dr	date	linear	.XX±.01/0.X±0.3			COPY		title	
A	V03-0471	TAB	04/28/03	linear	.XXX±.005/0.XX±0.13			projection		4P + 28S + 4P	
B	DG05-0123	SJ	05/23/05	angles	.XXX±.0020/0.XX±0.051					R/A SOLDER RECEPTACLE	
				dr	T. BRUNGARD	04/28/03	INCH/MM		product family		code
				enr	W. MOSTOLLER	04/28/03	A		PwrBlade		213
				chr	W. MOSTOLLER	04/28/03	scale		size		sheet
				appd	W. MOSTOLLER	04/28/03	1:1		51915-025		1 of 4
sheet index	revision sheet	B	B	B	B	B					B
		1	2	3	4						

Pro/E

cage code 22526

PDM: Rev:B

STATUS: Released

Printed: Aug 15, 2007

Tous droits strictement réservés. Reproduction ou communication o des tiers interdite sous quelque forme que ce soit sans autorisation écrite du propriétaire. Propriété de c FCI. Droits de reproduction FCI.

All rights strictly reserved. Reproduction or issue to third parties in any form whatever is not permitted without written authority from the proprietor. Property of FCI. Copyright FCI.

PRODUCT NUMBER
51915-025--
 Note: ③

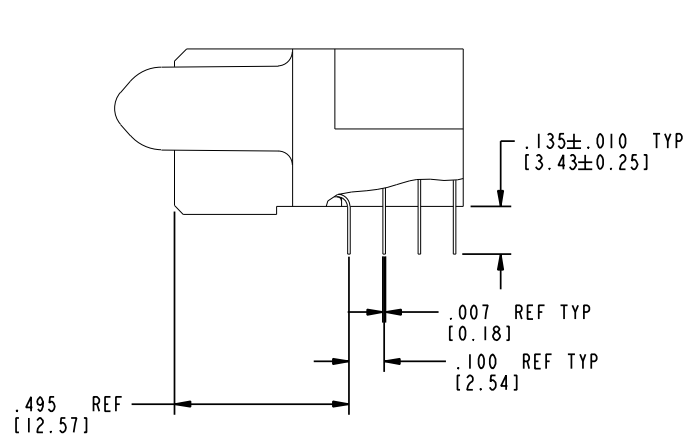

BROKEN-OUT SECTION A-A
 SCALE 2:1

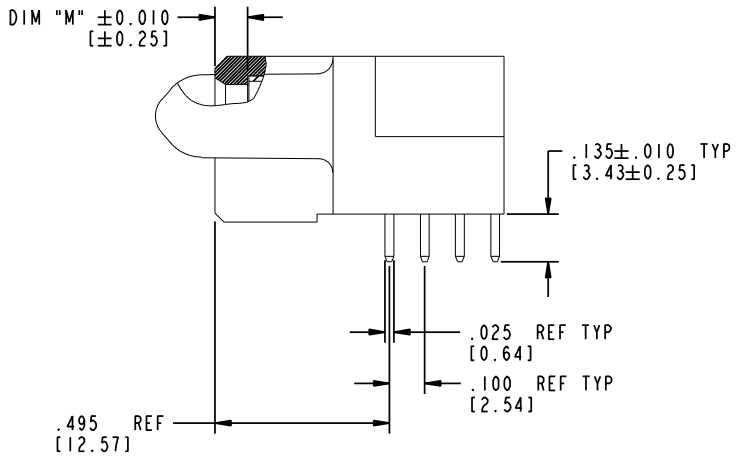

BROKEN-OUT SECTION B-B
 SCALE 2:1

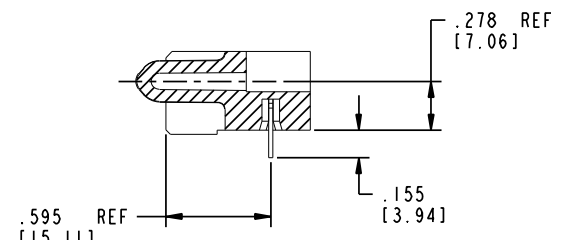

SECTION C-C

mat'l code		SEE NOTE 2		tolerances unless otherwise specified		CUSTOMER		 www.fciconnect.com	
ltr	ecn no.	dr	date	linear	.XX±.01/0.X±0.3	COPY		projection	title
B				angles	.XXX±.005/0.XX±0.13	INCH/MM		 product family PwrBlade code 213 size dwg no 51915-025 sheet 2 of 4	
				dr	.XXX±.0020/0.XX±0.051	scale 1:1			
				enr	0±2°	T. BRUNGARD 04/28/03			
				chr		W. MOSTOLLER 04/28/03			
				appd		W. MOSTOLLER 04/28/03			
sheet index	revision sheet								

cage code **22526**

Pro/E

PDM: Rev:B

STATUS: Released

Printed: Aug 15, 2007

Tous droits strictement réservés. Reproduction ou communication o des tiers interdite sous quelque forme que ce soit sans autorisation écrite du propriétaire. Propriété de c FCI. Droits de reproduction FCI.

All rights strictly reserved. Reproduction or issue to third parties in any form whatever is not permitted without written authority from the proprietor. Property of FCI. Copyright FCI.

PRODUCT NUMBER
51915-025--
 Note: ③

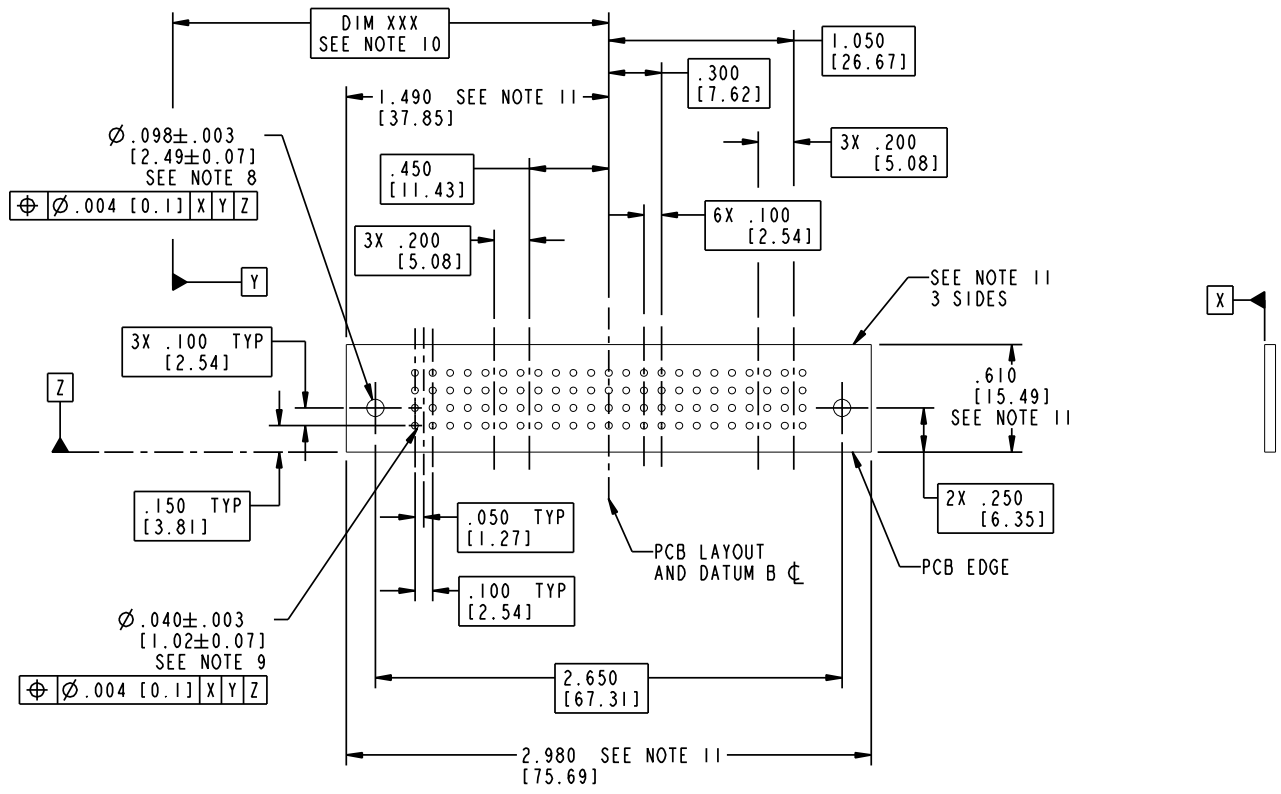

A
FCI

mat'l code		SEE NOTE 2		tolerances unless otherwise specified		CUSTOMER		A FCI www.fciconnect.com	
ltr	ecn no.	dr	date	linear	.XX±.01/0.X±0.3	COPY		projection	
B				angles	.XXX±.005/0.XX±0.13	INCH/MM		title	
				dr	.XXX±.002/0.XX±0.051	scale		4P + 28S + 4P	
				enr	0° ± 2°	1:1		R/A SOLDER RECEPTACLE	
				chr	T. BRUNGARD 04/28/03	product family		PwrBlade	
				appd	M. MOSTOLLER 04/28/03	size		code	
					M. MOSTOLLER 04/28/03	A		213	
sheet index	revision sheet					51915-025		3 of 4	

Pro/E

cage code **22526**

PDM: Rev:B

STATUS: Released

Printed: Aug 15, 2007

Tous droits strictement réservés. Reproduction ou communication o des tiers interdite sous quelque forme que ce soit sans autorisation écrite du propriétaire. Propriété de c FCI. Droits de reproduction FCI.

FCI

All rights strictly reserved. Reproduction or issue to third parties in any form whatever is not permitted without written authority from the proprietor. Property of FCI. Copyright FCI.

PRODUCT NUMBER
51915-025
Note: ③

NOTES:

1. DIMENSIONS AND TOLERANCES ARE IN ACCORDANCE WITH ASME Y14.5M, 1994 UNLESS OTHERWISE SPECIFIED.

CONNECTOR NOTES:

②. HOUSING MATERIAL: UL 94 V-0 GLASS FILLED

HIGH-TEMP THERMOPLASTIC
POWER CONTACT MATERIAL: COPPER ALLOY
SIGNAL PIN MATERIAL: COPPER ALLOY

3. PLATING:

51915-025 Singal Pin:30u"/0.76um Au OVER 50u"/1.27um Ni ON THE CONTACT AREA,
AND 100u"/2.54um SnPb PLATING OVER 50u"/1.27um Ni ON THE TERMINATION SECTION.
Power Pin:30u"/0.76um Au OVER 50u"/1.27um Ni ON THE CONTACT AREA,
AND 100u"/2.54um SnPb PLATING OVER 50u"/1.27um Ni ON THE TERMINATION SECTION.

51915-025LF Singal Pin:30u"/0.76um Au OVER 50u"/1.27um Ni ON THE CONTACT AREA,
AND 78u"/2.00um Sn PLATING OVER 50u"/1.27um Ni ON THE TERMINATION SECTION.
Power Pin:30u"/0.76um Au OVER 50u"/1.27um Ni ON THE CONTACT AREA,
AND 78u"/2.00um Sn PLATING OVER 50u"/1.27um Ni ON THE TERMINATION SECTION.

PART NUMBER 51915-025LF MEETS EUROPEAN UNION DIRECTIVE AND OTHER COUNTRY REGULATIONS AS DESCRIBED IN GS-22-008.

THE HOUSING WILL WITHSTAND EXPOSURE TO 260° PEAK TEMPERATURE FOR 10 SECONDS IN A WAVE SOLDER APPLICATION WITH A CIRCUIT BOARD.

④. MANUFACTURER'S NAME, P/N, AND DATE CODE TO APPEAR ON THIS SURFACE.

5. PRODUCT SPECIFICATION GS-12-149.
APPLICATION SPECIFICATION BUS-20-067.

6. PACKAGED IN TRAYS.

PCB NOTES:



7. ALL HOLE DIAMETERS ARE FINISHED HOLE SIZE.

⑧. MOUNTING HOLES, WHERE APPLICABLE, ARE UNPLATED.

⑨. $\varnothing .0453 \pm .0010$ [1.151 ± 0.025] DRILLED HOLES PLATED WITH
.0003 [0.008] MIN SnPb OVER .001 [0.03]
TO .003 [0.08] Cu PLATING TO ACHIEVE
 $\varnothing .040 \pm .003$ [1.02 ± .07] HOLE.

⑩. "DIM XXX" TO BE DETERMINED BY THE CUSTOMER.

⑪. CONNECTOR KEEP-OUT ZONE.

mat'l code				SEE NOTE 2		tolerances unless otherwise specified		CUSTOMER		 www.fciconnect.com	
ltr	ecn no.	dr	date	linear	.XX±.01/0.X±0.3	COPY		projection		title	
B				angles	.XXX±.005/0.XX±0.13					4P + 28S + 4P R/A SOLDER RECEPTACLE	
				dr	.XXX±.002/0.XX±0.051			INCH/MM		product family	
				enr	0 ± 2°			scale		PwrBlade	
				chr	T. BRUNGARD 04/28/03			1:1		code	
				appd	M. MOSTOLLER 04/28/03			A		213	
					M. MOSTOLLER 04/28/03					sheet	
										4 of 4	
sheet index	revision sheet										

Pro/E

cage code 22526

PDM: Rev:B

STATUS: Released

Printed: Aug 15, 2007